

DESCRIPTION:
 BRASS, FLANGE 5 1/4" DIAMETER
 [3] 8/32 X 1.23 MOUNTING SCREW INCLUDED

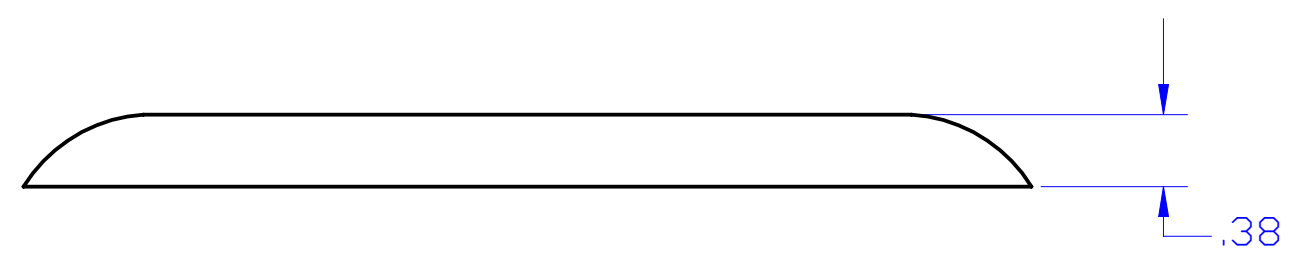
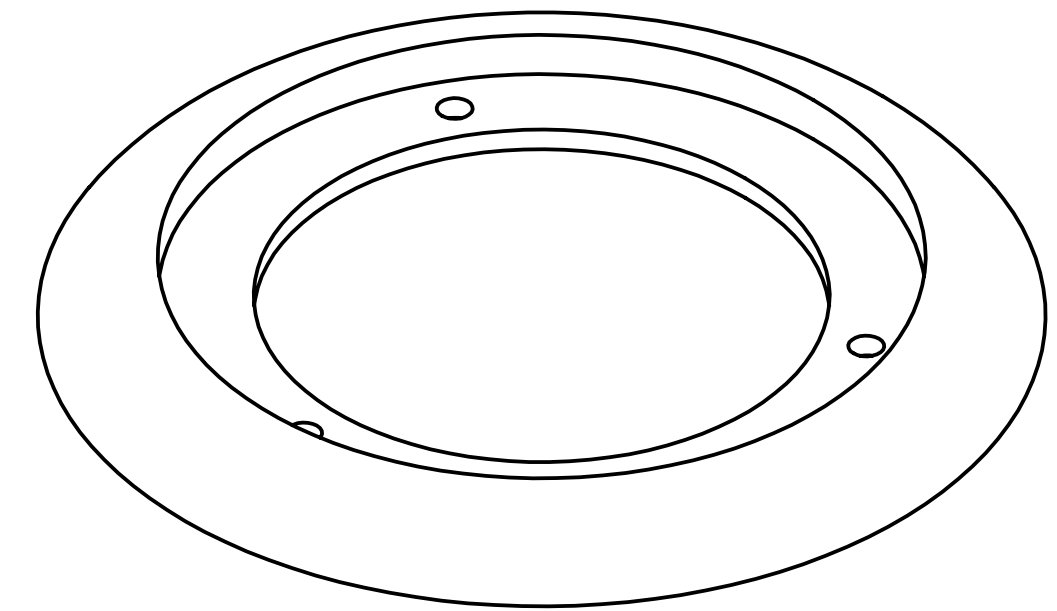
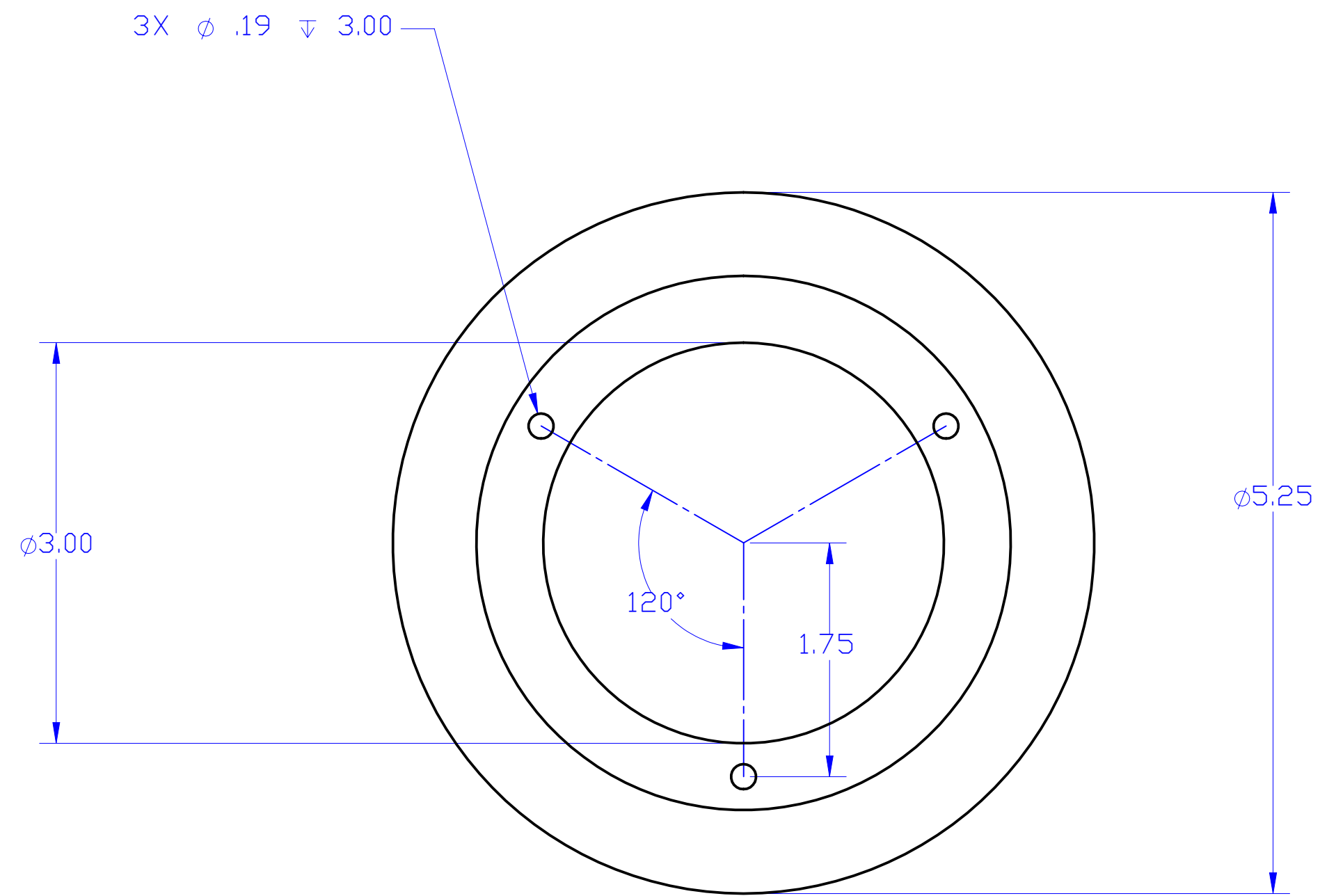

LEW ELECTRIC
FITTINGS COMPANY
 SERVING THE ELECTRICAL INDUSTRY SINCE 1901
 371 Randy Road, Carol Stream, IL 60188
 PHONE: 630.665.2075

UNLESS OTHERWISE SPECIFIED:	NAME	DATE	TITLE: SCF-1
DIMENSIONS ARE IN INCHES	DRAWN	P.J.G.	
TOLERANCES:			SIZE DWG. NO. REV C 100157 A
FRACTIONAL ±			
ANGULAR: MACH ± BEND ±			
TWO PLACE DECIMAL ±			WEIGHT: SHEET 7 OF 8
THREE PLACE DECIMAL ±			
INTERPRET GEOMETRIC TOLERANCING PER:	COMMENTS:		
MATERIAL			
FINISH			
DO NOT SCALE DRAWING			